

MIL-STD-1553B Component



Minuet

**For 1553 Remote Terminal,
Bus Controller and Monitor applications**

**Compact, Robust, Reliable
MIL-STD-Products**

Specifications

Compatibility

- MIL-STD-1553B Notice 2
- DDC® Enhanced MiniACE® software drivers
- PCI Target; 33/66MHz

Available Configurations

- **MIL-STD-1553 Configuration**
 - Mil-Std-1553 Bus Controller
 - Mil-Std-1553 Remote Terminal and Monitor
- **Packaging**
 - Lead-Free 132-Ball csBGA (8x8mm)
 - Lead-Free 256-Ball ftBGA (17x17mm)
- **Back-End Interface**
 - PCI Target, 32 bits, 33/66 Mhz (with Burst Mode)
 - Address/Data Local Bus
- **Clock Frequency**
 - 16MHz by default or PCI clock
 - Wide range of frequencies available by setting the clock register
- **Memory**
 - 8K or 16K x 16 bits Internal memory
- **All devices**
 - Temperature range: -40°C to +85°C Industrial
 - Power: 3.3 and 1.2 VDC

More 1553 products from Sital:

- MIL-STD-1553 IP Cores for FPGAs.
- MIL-STD-1553 Discrete Components Transceiver
- MIL-STD-1553 Transformers
- MIL-STD-1553 Couplers
- Mil-Std-1553 Testers
- 2-8 channels 1553, PCI boards

Key Features and Benefits

- MIL-STD-1553B Notice 2 compliant terminals
- Software compatible with DDC® Enhanced MiniACE®
- Smallest solution available - 8x8mm or 17x17mm BGA.
- PCI or Local Bus interface
- 3.3V and 1.2V operation, very low power consumption.
- Operates from wide range of clock frequencies
- Flexible pinout configuration for easy PCB layout
- Very fast access 8Kx16 or 16Kx16 bits Shared RAM
- Bootable RT option required for MIL-STD-1760
- Simultaneous RT/MT Mode
- PCI Evaluation board available



Minuet™ is a family of 8mm or 17mm Square, standalone, Mil-Std-1553B protocol terminals that include Bus Controller (BC), Remote Terminal (RT) and Monitor (MT). Depending on the configuration, Minuet can be configured as BC/RT/MT or RT+MT.

Minuet™ devices are software compatible with DDC® Enhanced MiniACE® components and architecture, with 8K or 16K Words of internal memory.

Operating Clock frequency is flexible. A wide range of frequencies are available and selectable by writing to a register within the device. This eliminates long bus cycles and reduces EMI/RFI problems often caused by multiple clock domains on boards.

Users can select between Local Bus or PCI interface supporting 32 bits, 66MHz, PCI burst mode for very fast data transfer to and from the device.

More information available at www.sitaltech.com

Email: sales@sitaltech.com

* DDC® and MINI-ACE® are registered trademarks of Data Device Corporation, Bohemia, NY, USA. There is no affiliation between Data Device Corporation and Sital technology, Ltd.

Sital Technology Ltd.
17 Atir-Yeda St, Kfar-Saba, Israel
Tel.: +972-9-7633300

Minuet Mil-Std-1553B Terminal

Deliverables

Minuet™ Components

- **PN: MNT1553PCI-8-LF**
 - 132-Ball csBGA (8x8 mm)
 - Lead-Free
 - 0.5mm Pitch
 - 8K x 16 bits internal RAM
 - 32 bit PCI interface
- **PN: MNT1553LB-8-LF**
 - 256-Ball ftBGA (17x17 mm)
 - Lead-Free
 - 1 mm Pitch
 - 8K x 16 bits internal RAM
 - 16 bit Local-Bus Interface
- **PN: MNT1553PCI-16-LF**
 - 256-Ball ftBGA (17x17 mm)
 - Lead-Free
 - 1 mm Pitch
 - 16K x 16 bit internal RAM
 - 32 bits PCI interface
- **PN: MNT1553LB-16-LF**
 - 256-Ball ftBGA (17x17 mm)
 - Lead-Free
 - 1 mm Pitch
 - 16K x 16 bit internal RAM
 - 16 bit Local-Bus interface

- **Other configurations available.**
See Minuet™ datasheet for details

Software

- Software drivers and API for Windows. Source code can be provided for modification to other RTOS.

Minuet™ Evaluation Kit

- BRD1553PCI - PCI board, with Minuet™ component
- Luthier Com Builder, Software for 1553 Scenario definition and test.

Sital Technology Ltd.

Tel: +972-9-7633300
Fax: +972-9-7663394

Email: info@sitaltech.com
Web: www.sitaltech.com



Back-End Interface

The Minuet™ family is built from a Non-volatile Flash based Field Programmable Gate Array (FPGA) pre-loaded with Sital's proven DDC® compatible IP core for Mil-Std-1553 interface and Sital's PCI Target core.

Customers can select between local CPU bus interface or connect directly to a PCI bus. Customers can also request special pin configurations to better accommodate customer's PCB layout.

The memory and register management scheme is compatible with DDC® Enhanced Mini ACE® so that existing software drivers, developed for DDC® components can work seamlessly with Minuet™ devices. Minuet™ devices can optionally boot-up as a RT with the Busy bit set for 1760 applications.

Package Information

8mm, 132-Ball csBGA Package

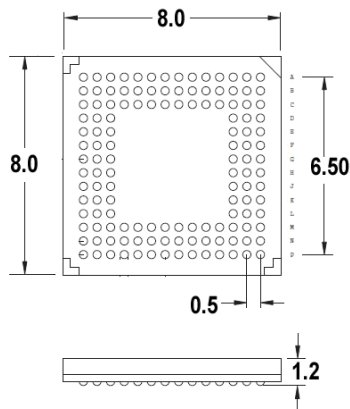

* Dimensions are in millimeters

17mm, 256-Ball ftBGA Package

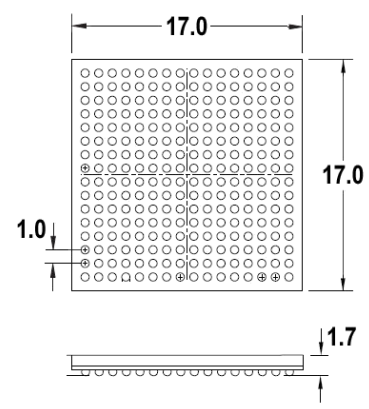

* Bottom and side view

Interface to the 1553 Bus

Minuet™ components require external 1553 Transceiver and a coupling transformer.

Minuet™ can work with any existing 1553 transceiver available in the market. It can also work alongside with Sital's discrete Transceiver for cost saving.

A "Transceiver_Select" pin is used to select between a standard transceiver and Sital's discrete transceiver.

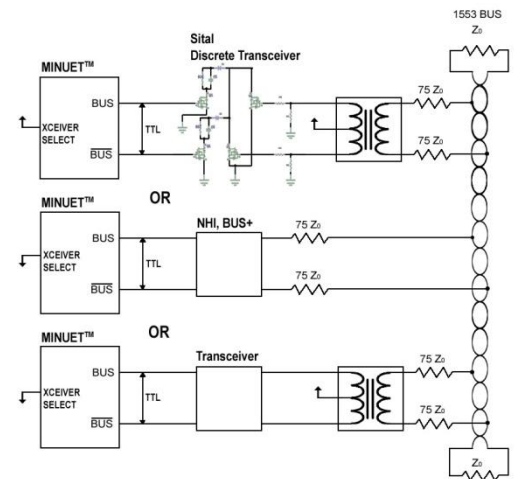

About Sital

Sital Technology provides world-class products and expertise for communication bus applications in the avionics, aerospace and automotive industries. Sital embeds its vast experience and proficiency in its products which include Mil-Std-1553 and other avionics IP cores, components, boards and testers, as well as CAN bus devices and applications. With its highly-experienced staff of experts, the company's Projects Division undertakes design, integration and turn-key engagements on behalf of the world's leading commercial and military avionics companies, space agencies, and automobile designers and manufacturers. Sital's bus technologies and expertise improve robustness and efficiency as they lower cost, space and resource utilization.

Sital's formidable customer list includes leading military and commercial organizations throughout the world among them: NASA, Boeing, Lockheed-Martin, Honeywell, Raytheon, General Motors, British Aerospace, Orbital Science, Thales, ECIL(India), Aselsan, Elbit, Rafael and IAI.