

## MIL-STD-1553 Coupler

SITAL's 1553 coupler (CPLR1553STL-06) is a dual, three stub MIL-STD-1553B/1760 coupler. Each coupler has an optional internal termination. The coupler is designed to provide 3 stubs with termination for bus A, another for B, or concatenated to a single 6 stub coupler for a single bus. The coupler offers a unique, innovative low profile mechanical structure that supports PCI & cPCI (PXI) mechanical fitting. This feature enables denser and optimized organization of rack mounted testers. All connections and termination enablement is via a standard D-Type 25 plug. When termination is engaged, an LED lights up during live messaging, reflecting bus activity and utilization.

## Features

- Can be configured as a single 6-Stub coupler
- MIL-PRF 21038/27 Internal Transformers
- Excellent performance encapsulating new technologies
- Unique PCI or cPCI Rack Assemblies Fitting
- Flexible Mechanical support for other rack assembly Fitting
- Lower system cost – saves wires & Triax plugs
- Low profile & Light Weight
- Termination enabled by shortening two terminals
- LED activity indication per terminated coupler
- Epoxy casting and finish for lifetime support

# Dual, 3 stubs MIL-STD-1553 Coupler



## Connecting the coupler to your system

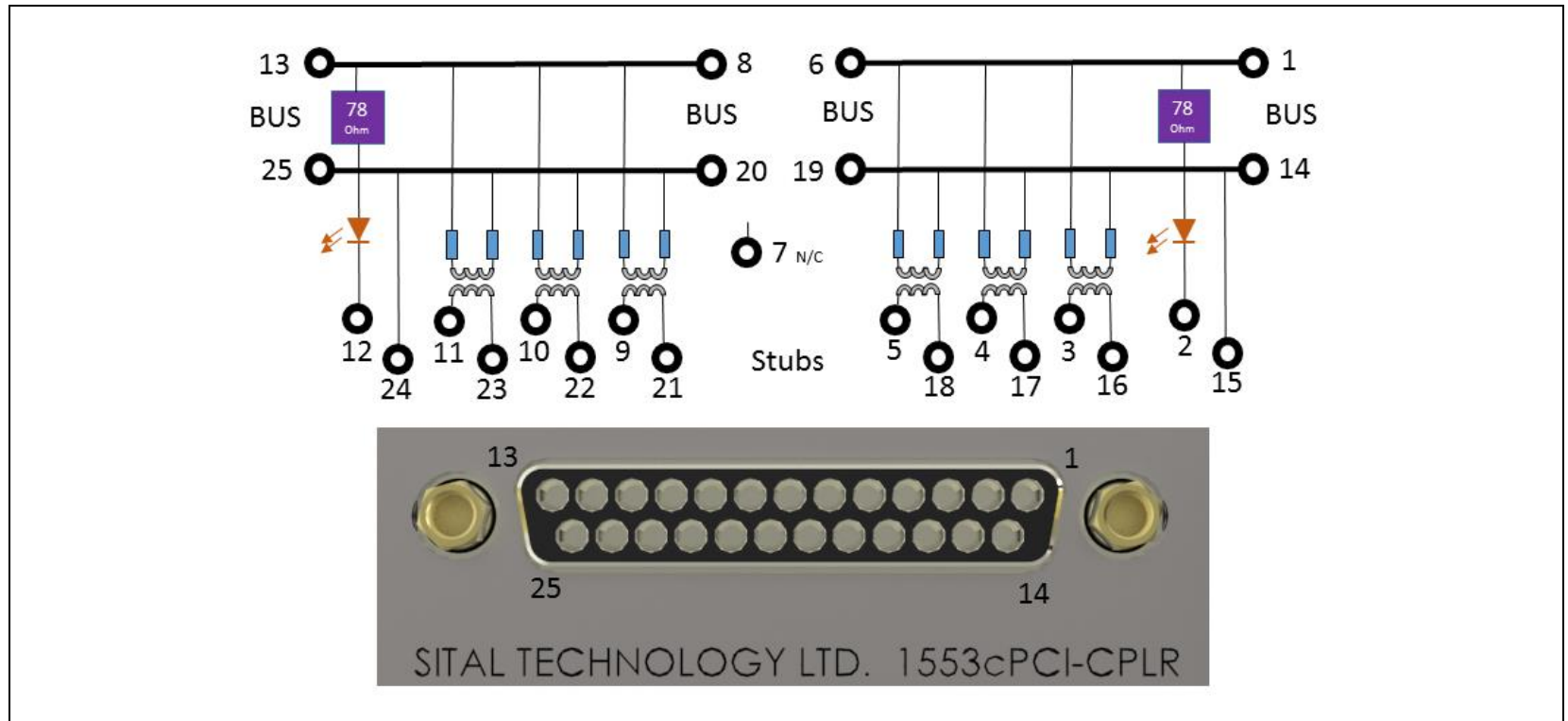

The dual 3-stub coupler (as seen in the above diagram) connects with the pins of the 25-Pin D-Type female connector.

The upper row, pins 1 through 13, connect to the high-side of the MIL-STD-1553 wires. The lower row connects with the complementary wires of the MIL-STD-1553 bus.

If a single 6-stub coupler is required, use a jumper to connect pins 6 and 8, as well as pins 19 and 20. In any format, only one termination is required at the end of the coupler for proper MIL-STD-1553.

# Mechanical Drawings

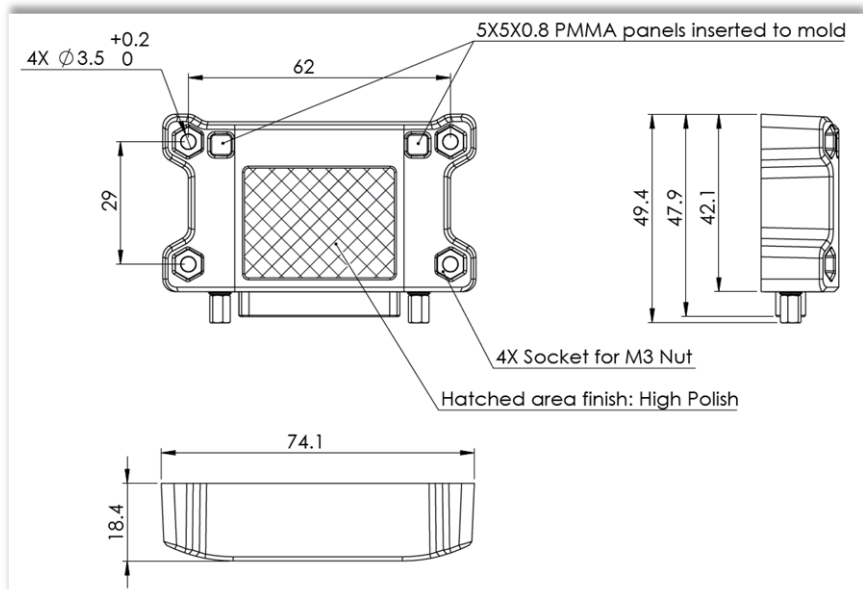

Material: Black, TPU90 Shore A, Over molded on Electronics.

## Ordering Options & Codes

### CPLR1553STL-06

The base dual 3-Stub coupler, ready for panel mount.

Connect either the 4 screws or the D-Type connector screws.



### CPLR1553STL-06-PCI

The base dual 3-stub coupler mounted to a standard PC back panel for easy integration inside PC housing.

The coupler does not interact with the various slots inside the PC housing.



### CPLR1553STL-06-PXI

The base dual 3-stub coupler mounted to a standard PC back panel for easy integration inside 3U cPCI / PXI housing.

The coupler does not interact with the various slots inside



### CPLR1553STL-12-PNL-6U

2 x base dual 3-stub coupler mounted to a standard 6U back panel for easy integration inside 6U VME / VPX housing.

The coupler does not interact with the various slots inside.



# Configuration Notes

## Terminating a 1553 bus

Some designers terminate couplers at each end with a 78 Ohm load. This approach is incorrect and often results in overloading the stubbed units. Placing two terminations can be attributed to following 'bad practice,' trying to achieve better results when one of the stub units transmits a bad signal, or misunderstanding the physical layer of 1553 and proper coupling strategies in general.

Below is a short explanation of the physical layer and its coupling, and why each coupler requires a single termination of 78 Ohm.

When a stub node transmits a message, it introduces a voltage difference between the wires. The wires, with a typical resistance of 78 Ohm, yield a current in proportion to the voltage, divided by 78. This current runs through the wires and couplers until they reach a termination resistor with 78 Ohm (actual, not typical). The transmitted current turns into heat and, more importantly, nothing echoes back to the transmitter to distort the signal and lower the noise margin.

If units are wired to communicate from both ends of the bus, each transmitter must have a 78 Ohm terminator at each end of the bus.

However, if the whole "system" is connected with a single coupler, there is no wiring, no typical impedance, and only a single 78 Ohm resistor is required.

Placing termination resistors on each end of a coupler creates a resistor load of 39 Ohm; this does not match the stubs wiring typical impedance of 78 Ohm, thus creating echoes back to the stub units, lowering the noise margin and hurting the signal's quality.

If you have a larger two coupler system with a wired connection between them, both couplers require only a single, 78 Ohm termination.